



# Defender<sup>®</sup> 2000

Bench Scales



**GC Weighing  
& Calibrations**  
*don't weight to call*

0474 30 40 50

## ***Designed for Dependability and Durability at a Practical Price!***

The OHAUS Defender 2000 Series of bench scales offers OHAUS' signature accuracy for commercial and industrial weighing applications at an unbeatable price. Depend on the OHAUS Defender 2000 Series when you need accuracy you can count on while maximizing your budget.

### ***Standard Features Include:***

- **Sturdy Industrial Design that Can Stand Up to the Rigors of Industrial Weighing**—The polished 430 stainless steel platform with painted carbon steel frame and aluminum alloy IP65 load cell provide strength and durability.
- **Easy-to-Read Red LED Display Can Be Viewed in Even the Dimmest Industrial Conditions**—Defender 2000's red LED indicator clearly displays results that can be seen in locations with less than optimal lighting.
- **Versatile Power Capabilities Provide Unrestricted Operation Wherever Your Weighing Needs Are**—An AC adapter and internal rechargeable lead acid battery provide options for powering your Defender 2000.



# Defender<sup>®</sup> 2000 Bench Scales

Model	D24PE30FR	D24PE60FR	D24PE60FL	D24PE150FL	D24PE150FX	D24PE300FX	D24PE300FV	D24PE600FV
Certified Capacity × Readability	30 × 0.005 kg	60 × 0.01 kg	60 × 0.01 kg	150 × 0.02 kg	150 × 0.02 kg	300 × 0.05 kg	300 × 0.05 kg	600 × 0.1 kg
Recommended Disp. Resolution	1:6000	1:6000	1:6000	1:7500	1:7500	1:6000	1:6000	1:6000
Load Cell Protection	Aluminum alloy IP65							
Base Construction	Stainless Steel pan, painted carbon steel frame							
Platform Dimensions (W × D)	300 × 350 mm		400 × 500 mm		500 × 600 mm		600 × 800 mm	
Front View Dimensions (F1 × F2 × F3 × F4 × F5 × F6)	210 × 165 × 300 × 103 × 50 × 240 mm		210 × 165 × 400 × 115 × 50 × 315 mm		210 × 165 × 500 × 145 × 100 × 420 mm		210 × 165 × 600 × 170 × 100 × 522 mm	
Side View Dimensions (S1 × S2 × S3 × S4 × S5)	740 × 462 × 350 × 290 × 44 mm		940 × 612 × 500 × 435 × 44 mm		940 × 712 × 600 × 530 × 44 mm		1240 × 912 × 800 × 725 × 44 mm	
Column	500 mm		700 mm			1000 mm		
Leveling Component	Externally visible level bubble and adjustable leveling feet with locking nuts							
Safe Overload Capacity	125% of rated capacity							
Indicator Construction	ABS plastic housing							
Weighing Units	kg, g, lb							
Application Modes	Weighing, Parts Counting, Accumulation							
Display	6-digit, 7-segment red LED, 20 mm high digits							
Keyboard	4 function mechanical keys, raised, tactile							
Zero Range	2% or 100% of full scale capacity							
Tare Range	Full capacity by subtraction							
Stabilization Time	1 second							
Auto-Zero Tracking	Off, 0.5, 1 or 3 divisions							
Power	AC adapter with internal rechargeable lead-acid battery							
Battery Life	80 hours continuous use with 12 hour recharge time							
Calibration	5 kg to 100% of capacity, user selectable							
Interface	Optional RS232							
Operating Temperature Range	-10°C to 40°C							
Net Weight								
Shipping Weight	11 kg		15 kg		26 kg		40 kg	
Shipping Dimensions	13 kg		17 kg		29 kg		45 kg	
	745 × 420 × 185 mm		915 × 515 × 184 mm		1025 × 625 × 185 mm		1150 × 745 × 265 mm	

## Other Standard Features and Equipment

Indicator with ABS plastic housing, red LED display, tactile mechanical keys, optional RS232C with manual/continuous/interval printing, hardware configuration lockout switch, internal lead-acid rechargeable battery and AC adapter. Software included for parts counting mode with selectable sample sizes and weighing totalization (Accumulation) functions. Selectable span calibration points, averaging level, auto-zero tracking and battery saving auto-off. Stainless steel pan with painted carbon steel tubular frame, non-slip rubber leveling feet with locking nuts, externally visible level bubble, aluminum alloy IP65 load cell, down-stops for overload protection

## Compliance

- **Product Safety:** IEC/EN 61010-1
- **Electromagnetic Compatibility:** IEC/EN 61326-1 Class B, Basic environments

## Accessories

RS232 Kit .....	30101019	Folding Column Kit
.....	30101016	In-Use-Cover
.....	30101017	SF40A Impact Printer
.....	30045641	

## Dimensions

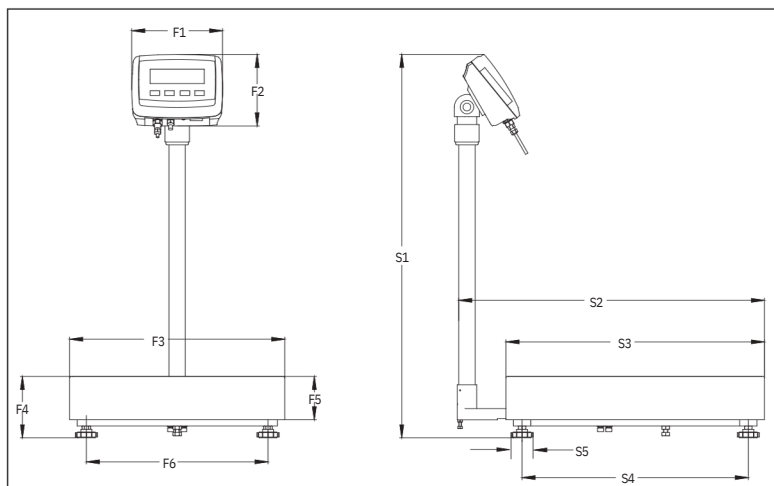

80774824 © Copyright OHAUS Corporation

## OHAUS CORPORATION

\* 7 Campus Drive  
Suite 310  
Parsippany, NJ 07054 USA

[www.ohaus.com](http://www.ohaus.com)

With offices throughout  
Europe, Asia, and  
Latin America

\*ISO 9001:2008

Registered Quality  
Management System

30248455

