



Pit-type Installation



Modular Design with galvanized structure

EZY LODEC SERIES

Modular Weighbridge System

Designed with a modular system for easy assembly, efficient shipping and adjustment of size. Ezy Lodec's galvanized structure provides full protection from rust and corrosion, reducing maintenance costs. Ezy Lodec is suitable for both above ground and pit-type applications, with the ability of being relocated at a later stage with ease.

- Easy installation with modular design
- Galvanized body structure
- Both; above ground & pit-type available
- Low profile (200mm)
- Equipped with WBK Load Cell



EZY LODEC | Modular Weighbridge System

Module Structure

Ezy Lodec's modular design reduces installation time and allows the weighbridge to expand in length with additional deck modules, reaching up to 24 meters. In addition; the modular design also allows for quick and easy relocation.

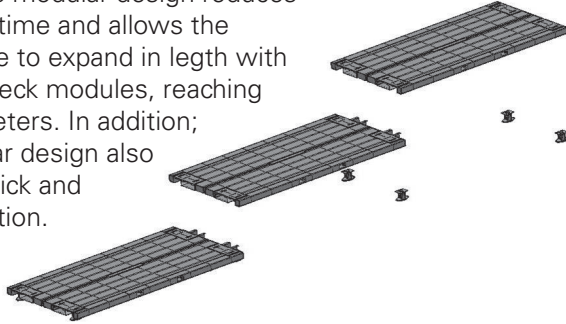

Galvanised Structure

By galvanizing the whole structure, ensures that all areas whether easily accessible or not are protected by preventing rust and corrosion. The galvanized coating is metallurgically bonded to the steel structure, preventing shrinkage or cracks appearing and provides superior resistance to abrasions and water. Galvanizing has proven to be cost effective in the long term as it needs less maintenance.



Type



Above ground

Easily installed above ground on any flat surface with minimum concrete foundations



Pit-type

Installed within the pit to provide smooth surface finish, while requiring less land space.

Specifications

TECHNICAL DATA

Segment Size A x B (mm)	Ezy Lodec Series		
	Max. Capacity (ton)	Min. Division (kg)	Load Cell Q'ty
3000 x 6000	30~60	10~20	4
3000 x 12000	30~60	10~20	6
3000 x 18000	30~60	10~20	8
3000 x 24000	30~60	10~20	12

FEATURES

- Easy installation with modular design
- Galvanized body structure
- Both; above ground & pit-type available
- Low profile (200mm)
- Equipped with WBK Load Cells

WEIGHBRIDGE LOAD CELLS



WBK Load Cell:

- OMIL Certified
- IP68 Protection class
- Stainless Steel Body & Hermetically sealed
- Lightning protected
- Ex ia IIC T6

CAS

UNIT 8, NORTHLINK, 459 TUFNELL ROAD
BANYO QLD 4014, AUSTRALIA

TEL: +61 (0)7 3267 7767 FAX: +61 (0)7 32 67 1818

EMAIL: sales@cassscale.com.au

<http://www.cassscale.com.au>

Specifications are subject to change for improvement without prior notice.