

BCA SERIES



Single Point - Load Cell
5kg / 10kg / 15kg / 20kg
30kg / 50kg / 75kg / 100kg



- Anodized Aluminium
- 6 wires connection
- Single Point
- Max. Platform 400 x 400 mm

IP65
 Dust proof and
 water-protected



Technical Specifications

Max Capacity (rated load)	kgf	5kg, 10kg, 15kg, 20kg, 30kg, 50kg, 75kg, 100kg
Rated Output	mV / V	2.0 ± 0.2
Zero Balance	mV / V	0.0 ± 0.1
Accuracy Class	-	C3
Combined Error	% R.O.	0.02
Repeatability	% R.O.	0.01
Creep for 30min.	% R.O.	0.017
Resolution	-	≤1/5000
Division	mV/V	0.0004
Temperature Effect on - Zero Value	%/10 °C	0.014
Temperature Effect on - Output Value	%/10 °C	0.011
Excitation - Recommended	V	10
Excitation - Maximum	V	15
Resistance - Input	Ω	400 ± 20
Resistance - Output	Ω	350 ± 3.5
Resistance - Insulation	MΩ	> 2000
Compensated Temperature Range	°C	-10 to +40
Operating Temperature Range	°C	-20 to +70
Safety Overload	% R.L	150%
Cable Specification	-	ø5 x 4p x 1M (Urethane)

Dimension

Unit in mm

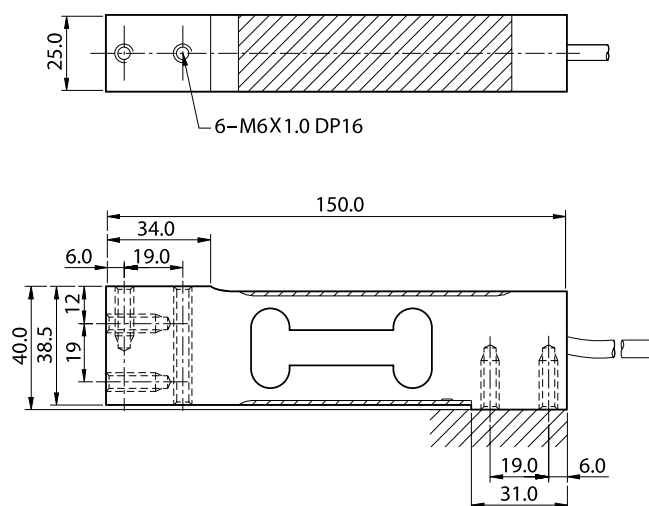

CAS

UNIT 8, NORTHLINK, 459 TUFNELL ROAD
 BANYO QLD 4014, AUSTRALIA

TEL: +61 (0)7 3267 7767 FAX: +61 (0)7 32 67 1818

EMAIL: sales@cassscale.com.au

<http://www.cassscale.com.au>

Specifications are subject to change for improvement without prior notice.

