



Used anywhere with battery power



Stackable



Load cell lock & adjustable footing

SH SERIES

Smart Weighing Scale

SH series is a simple weighing scale which offers high product versatility and reliability. Its simple design makes it easy to use and furthermore, its compact design and battery operation makes it ideal for use anywhere.

- Load cell lock & adjustable footing



SH SERIES | Smart Weighing Scale

SPECIFICATIONS

Model	SH Series		
Max. Capacity	200g	2,000g	5,000g
Readability	0.1g	1g	2g
External Resolution	1/2,000		1/2,500
Weighing Units	g, oz	g, lb: oz, oz t, dw t	
Display Digit	6 digits (weight)		
Display Type	LCD		
Operating Temp.	-18°C ~ 25°C		
Power	3 x AA batteries		
Battery Life	300hrs		
Plan Size (mm)	120		
Dimensions (mm)	145(W) x 45(D) x 205(H)		
Product Weight (kg)	0.4		

FEATURES

- Load cell lock function
- Possible to stack in storage without slipping
- Simple & easy to operate
- High contrast LCD display
- Battery or AC adaptor operation
- Auto power-off for low energy consumption
- Over / under load indicator

OPTIONS

- AC adaptor



Stackable

A molded stacking ring under the SH series allows several scales to be stacked in storage without slipping.



Load cell lock & adjustable footing

The load cell lock engineering protects SH series during transport and storage, while the adjustable footing provides great stability.

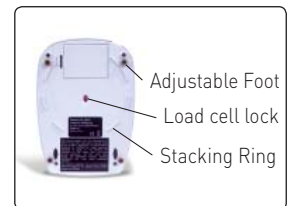

AC adaptor or battery power

Power the SH series by AC adaptor or AA alkaline batteries for approx. 300hrs of usage. Combined with its compact design the SH series ideal for use anywhere.



DIMENSIONS

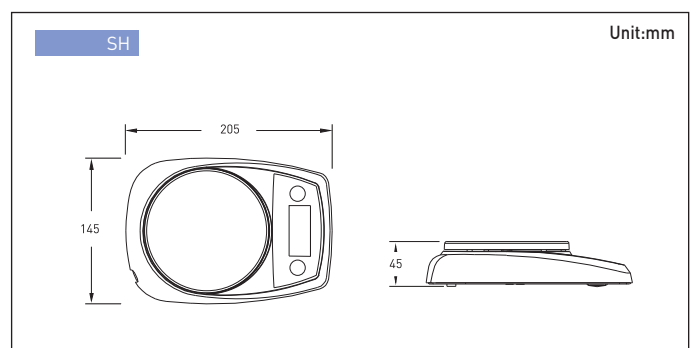

CAS

UNIT 8, NORTHLINK, 459 TUFNELL ROAD
 BANYO QLD 4014, AUSTRALIA
 TEL_ +61 7 3267 7767 FAX_ +61 7 3267 1818
 EMAIL_ sales@cassscale.com.au
www.cassscale.com.au

Specifications are subject to change for improvement without prior notice.